



14140 NE 200th ST. • Woodinville, WA. 98072 • PH: (425) 398-8282 • FX: (425) 398-8383

Procedure: Replacing the "Y" axis transmission body (300 - New carriage / 350HF)

Tools Required:

- 1/16" HEX Wrench
- 5/64" HEX Wrench
- 9/64" HEX Wrench
- Phillips tip screwdriver
- 11/32" socket and driver.

Removing the covers

- 1) Unplug the power, and computer cord from the back of the machine.
- 2) Remove the two (2) black "Phillips" screws on the right end plate, and one silver screw on the bottom of the cover. Remove the right cover by sliding it to the right and over the knobs.
- 3) Remove the two (2) black "Phillips" screws from the left end plate. Remove the left cover.

Loosen the "Y" axis drive belt

- 1) On the left side loosen the "Y" axis drive belt tensioner with a 9/64" HEX wrench. See Fig. 1
- 2) Un clip the belt clip from the carriage assembly. See Fig. 2

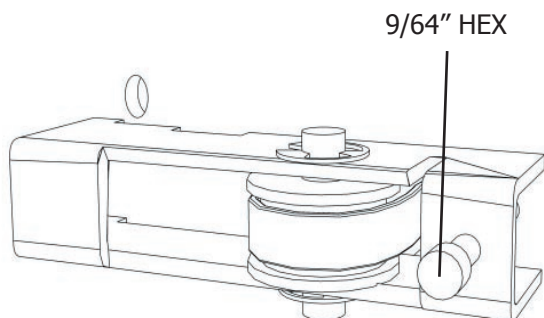

Fig. 1 - "Y" axis belt tensioner

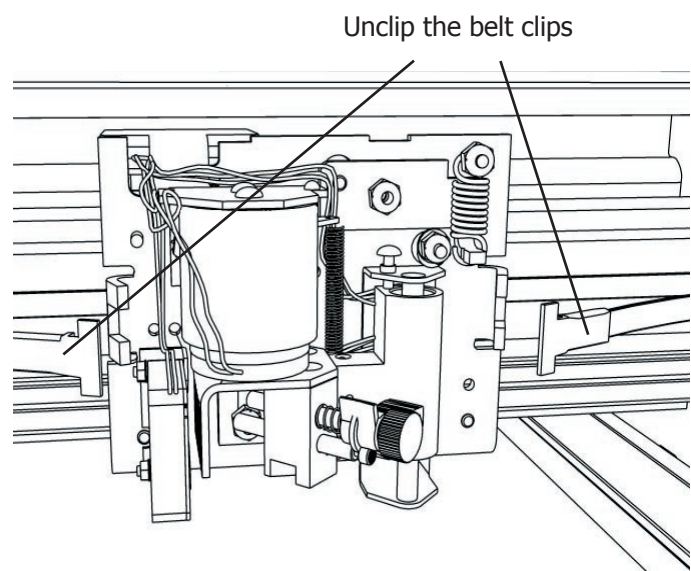

Fig. 2 -Removing the "Y" axis belt from the carriage

Removing the Transmission body

- 1) Unplug the wires from the motor. Two (2) power wires (Black & Yellow). One (1) encoder plug (Black plug in at the bottom of the motor).
- 2) With the 11/32" Socket & driver, remove the four (4) nuts holding the body of the transmission to the machine. See fig. 3
- 3) Pull the "Y" axis belt end through the hole in the end plate, and release it from the transmission gear. The transmission should be totally free from the machine now.

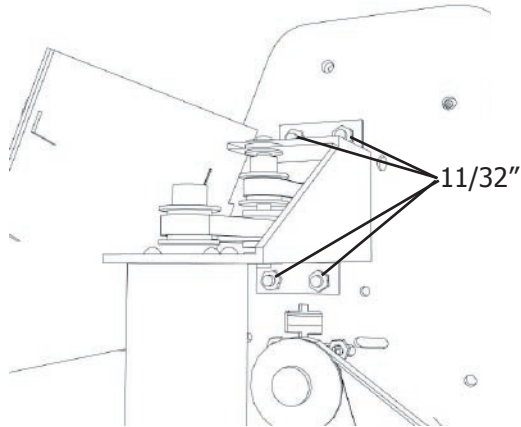

Fig. 3 - Transmission mounting nuts

Removing the motor

- 1) Loosen the two (2) 1/16" HEX screws located on the motor gear. See Fig. 4
- 2) Remove the three (3) 5/64" HEX screws below the motor gear. See Fig. 5
- 3) Remove the motor and the gear, set aside for now.

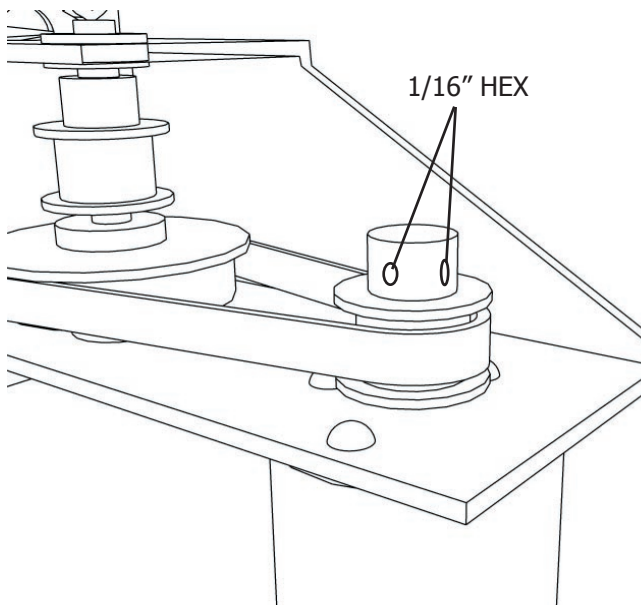

Fig. 4 - Motor gear setscrews

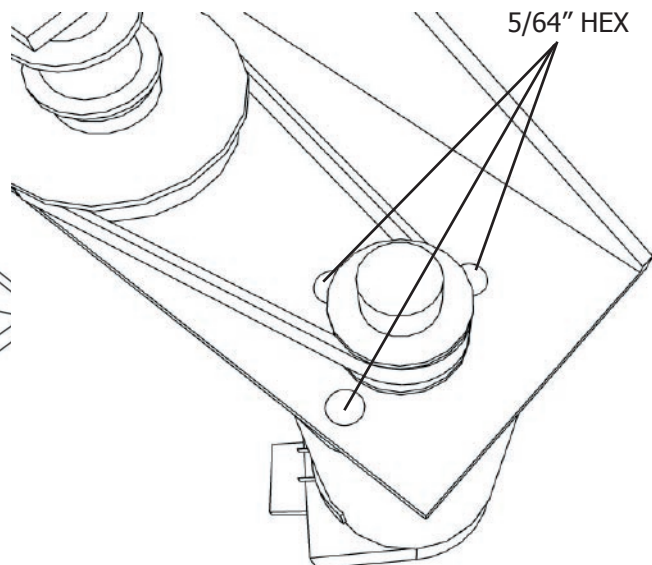

Fig. 5 - Motor mounting screws

Installing the motor to the body

- 1) Place the shaft of the motor through the hole in the new body. See fig. 6
- 2) Align the holes in the top of the motor with the three (3) holes on the body. The motor should be rotated so it looks like Fig. 7.

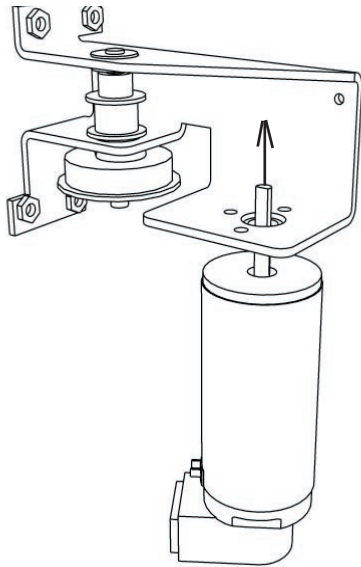

Fig. 6 - Installing the new motor

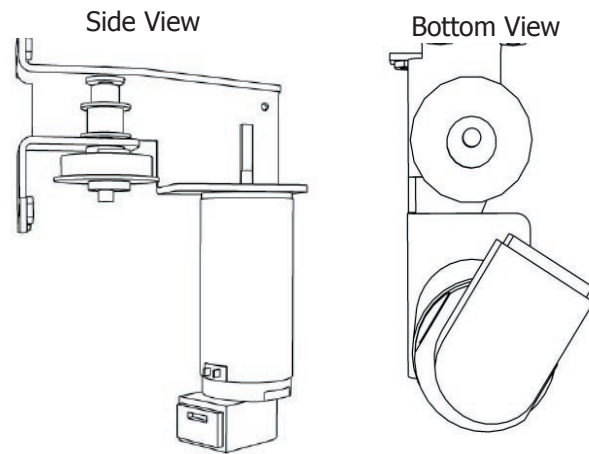

Fig. 7 - Proper motor position

- 3) Put one (1) screw in one of the outside holes, keep it a little loose. See fig. 8
- 4) Loop the timing belt around the large Gold gear on the transmission body.
- 5) Slide the motor gear onto the shaft of the motor. (This is the small gear you set aside earlier.) Don't tighten the screws on the gear.
- 6) Loop the belt around the motor gear by rotating the motor. If the motor mounting screw is too tight loosen it a little, and rotate the motor so the belt looks like fig. 9.

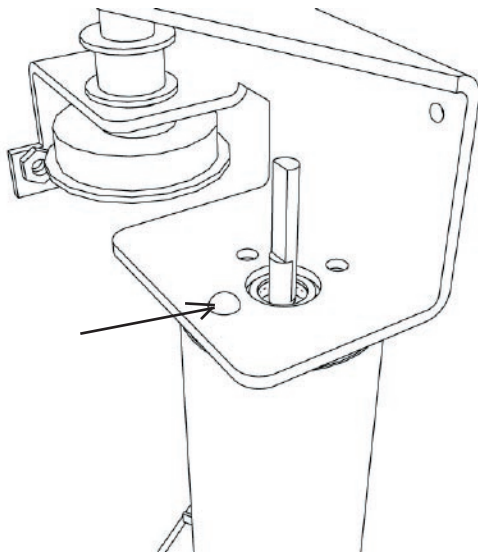

Fig. 8 - One screw to keep the motor in place

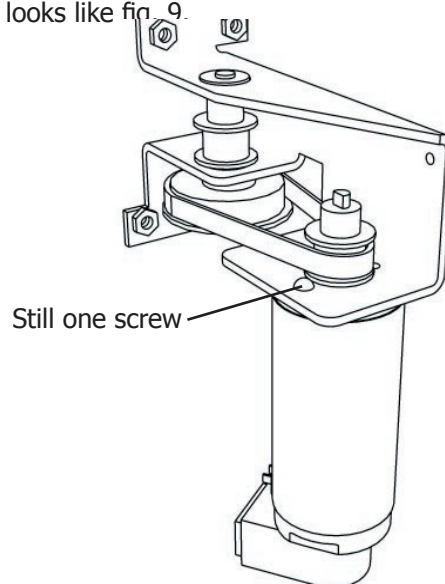
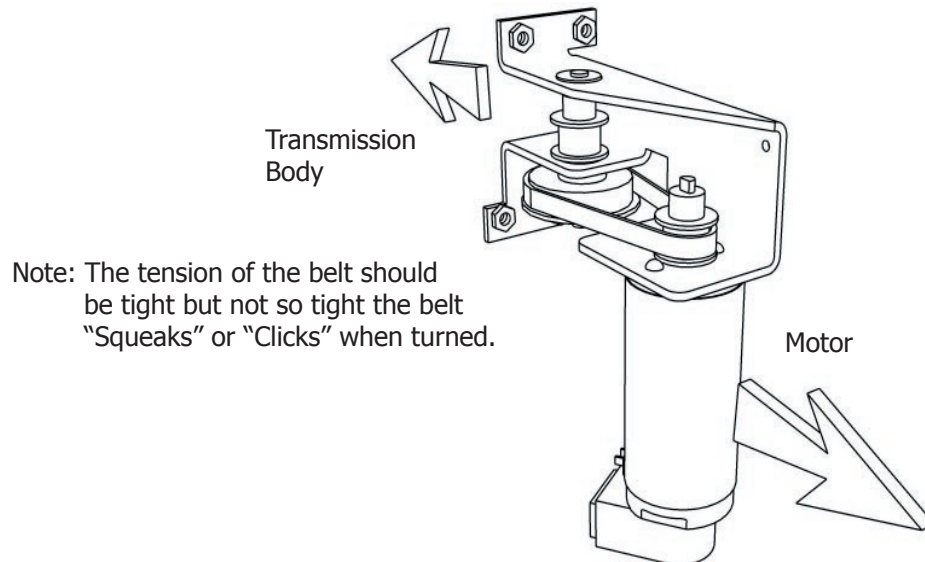

Fig. 9 - Belt and gear on

Tensioning the belt

- 1) Install the last two (2) 5/64" HEX screws to mount the motor to the transmission body. Leave them a little loose for now.
- 2) Tighten the belt by pulling the motor in the opposite direction from the body. See fig. 10



Note: The tension of the belt should be tight but not so tight the belt "Squeaks" or "Clicks" when turned.

Fig. 10 - Tension the belt by pushing the body of the transmission away from the motor

- 3) Tighten all three (3) 5/64" HEX motor mounting screws until they are fully snug.
- 4) Adjust the motor gear height so the belt is level and doesn't move up or down when the motor is turned. See fig. 11

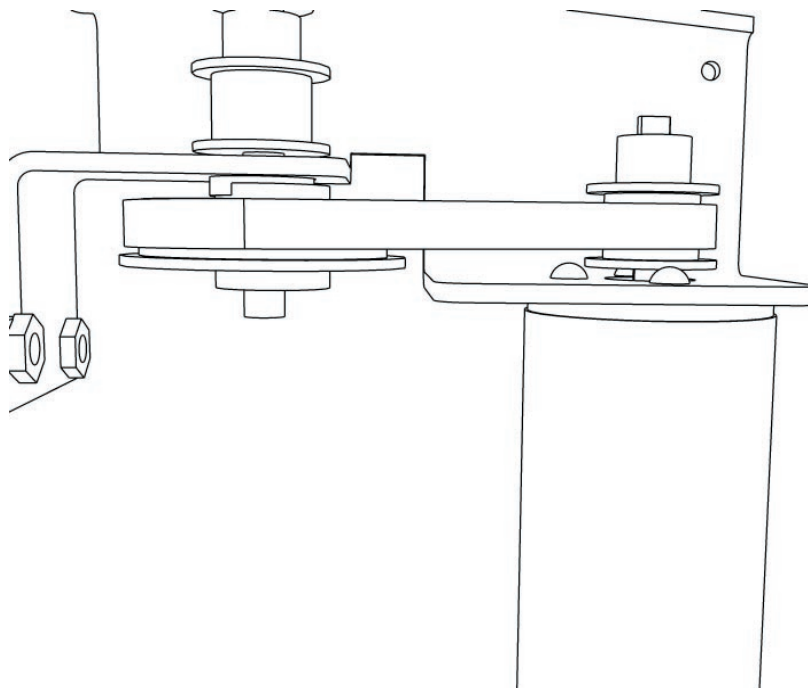

Fig. 11 - Belt is level with the transmission body when the motor is turned.

Install the transmission

- 1) Plug in the motor power wires (Black & Yellow) into the top two (2) lugs on the motor. Black is "-" (Negative), and Yellow is "+" (Positive). See fig. 12
- 2) Plug in the encoder wires into the bottom socket of the motor. This is the black plug with four (4) wires. Push it in until it clicks. See fig. 12
- 3) Find the end of the "Y" axis belt and put it around the top "Gold" gear on the transmission. Pull the end of the belt through the hole in the end plate of the cutter.
- 4) Install the transmission on the end plate of the cutter making sure you line up the holes on the transmission body with the studs on the end plate. Tighten the nuts on the studs until they are fully snug. See fig. 11

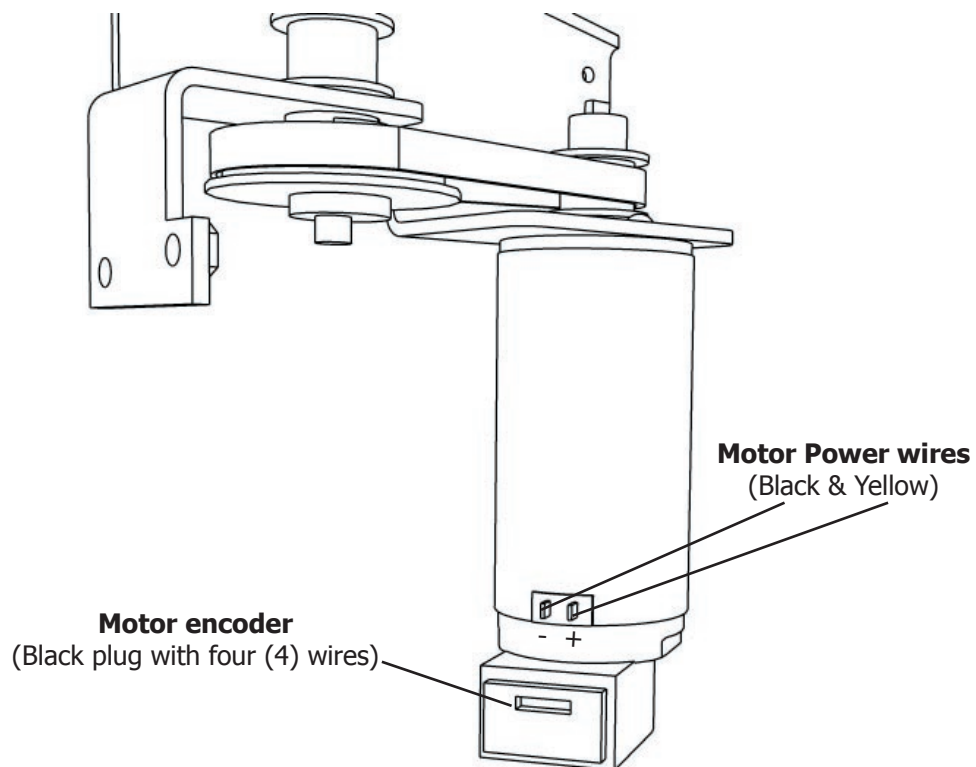
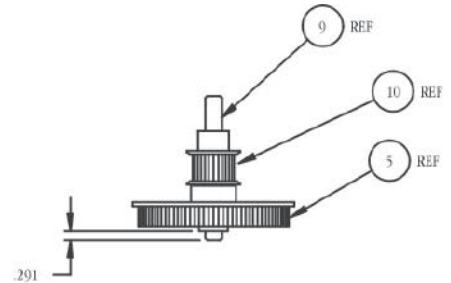
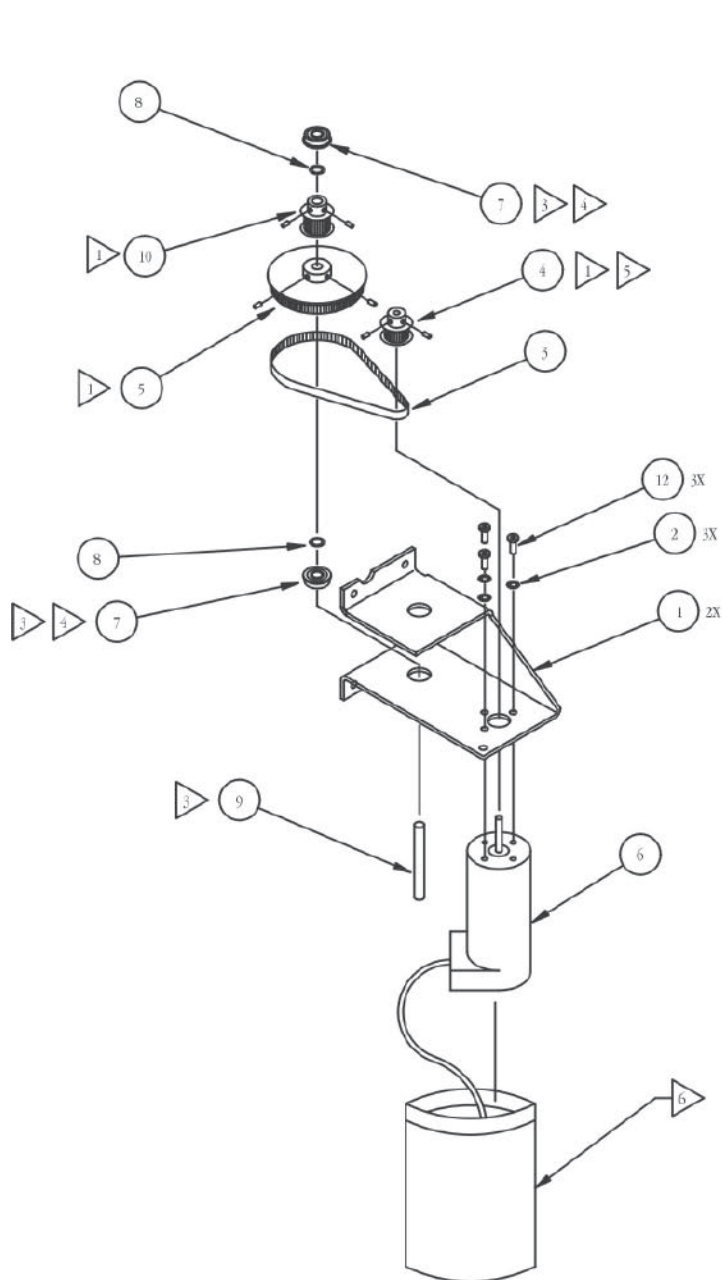

Fig. 12 - Wiring hookups

If problems occur call Ioline Tech Support for further assistance.

Original Transmission



NOTES:

- 1 SECURE ALL PULLEY SET SCREWS WITH LOCTITE 222. BE SURE ONE SET SCREW IS AGAINST FLAT ON SHAFT.
- 3 CLEAN MATING SURFACES OF BEARINGS, ITEM 7, AND PLATES, ITEM 1, WITH LOCTITE PRIMER N. SECURE BEARINGS TO PLATES WITH LOCTITE 609.
- 4 ADD A SMALL AMOUNT OF LOCTITE THREAD LOCKER 290 TO INNER RACE ID OF BEARINGS, ITEM 7. CAUTION: WIPE OFF ALL EXCESS LOCTITE. DO NOT ALLOW ANY TO GET INSIDE BEARING.
- 5 INSTALL PULLEY SO THAT THE GAP BETWEEN THE PULLEY FLANGE AND BRACKET IS $.100 \pm .010$.
- 6 MOTOR, ITEM 6, IS STATIC SENSITIVE. COVER MOTOR AND CONNECTOR WITH 3 X 5 STATIC BAG AND SECURE WITH A RUBBER BAND.



CAUTION
SENSITIVE ELECTRONIC DEVICES

DO NOT USE OR STORE NEAR OTHER
ELECTRONIC, ELECTRO-MAGNETIC,
MAGNETIC OR RADIO-FREQUENCY DEVICES.

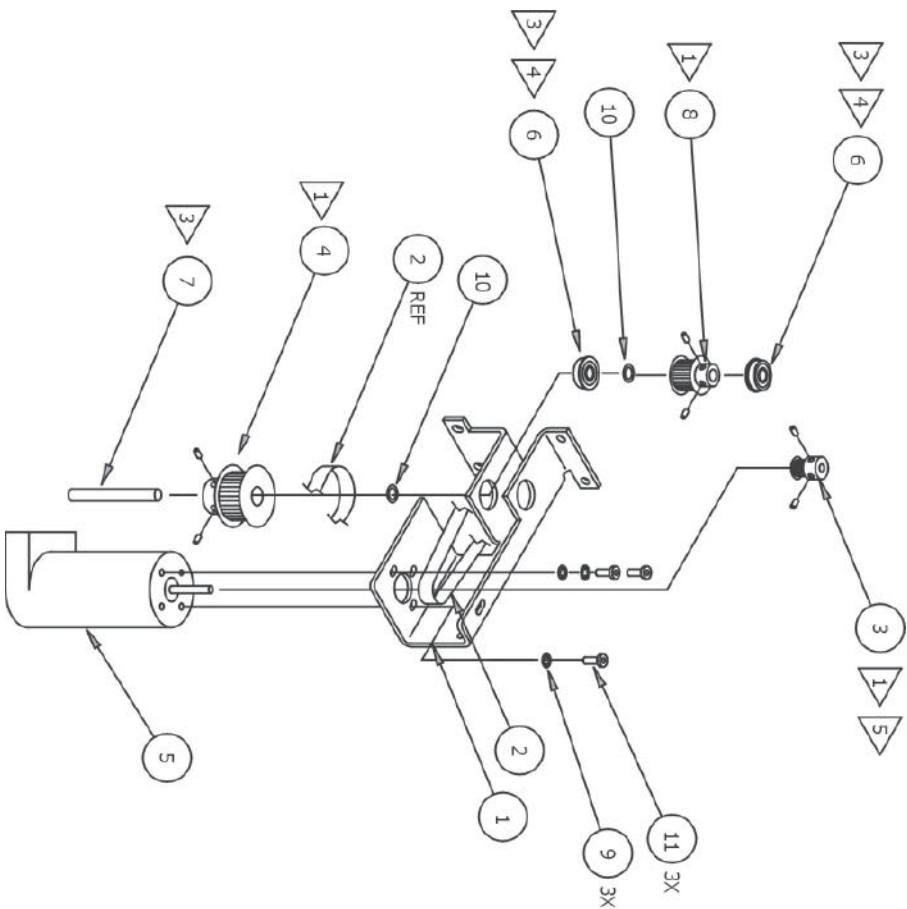

NOTES:

- 1 ▷ SECURE ALL PULLEY SET SCREWS WITH LOCTITE 222. BE SURE ONE SET SCREW IS AGAINST FLAT ON SHAFT.
- 3 ▷ CLEAN MATING SURFACES OF BEARINGS, ITEM 6, AND BRACKET, ITEM 1, WITH LOCTITE PRIMER N. SECURE BEARINGS TO BRACKET WITH LOCTITE 609 USING TOOL 107/50 AND SHAFT, ITEM 7, TO ALIGN BEARING. CAUTION: DO NOT LOCTITE SHAFT TO BEARING UNTIL NEXT STEP OF ASSEMBLY.
- 4 ▷ ADD A SMALL AMOUNT OF LOCTITE THREAD LOCKER 290 TO INNER RACE ID OF BEARINGS, ITEM 6. CAUTION: WIPE OFF ALL EXCESS LOCTITE. DO NOT ALLOW ANY TO GET INSIDE BEARING.
- 5 ▷ INSTALL PULLEY SO THAT THE GAP BETWEEN THE PULLEY FLANGE AND BRACKET IS .025±.010.



CAUTION

SENSITIVE ELECTRONIC DEVICES
DO NOT EXPOSE TO STATIC ELECTRICITY, ELECTROMAGNETIC INTERFERENCE, OR INDUCED TIME FIELDS

New Transmission