

IOLINE™



Quick Start Guide

SC Series
SC-72



IOLINE SMARTRAC™

USER NOTICE

Trademarks

Ioline and SmarTrac are trademarks of Ioline Corporation. Other product names, logos, designs, titles, words or phrases mentioned within this publication may be trademarks, service marks, or trade names of Ioline Corporation or other entities and may be registered in certain jurisdictions including internationally.

Ioline Disclaimer

IOLINE CORPORATION PROVIDES THIS MANUAL "AS IS" WITHOUT WARRANTY OF ANY KIND, EITHER EXPRESS OR IMPLIED, INCLUDING BUT NOT LIMITED TO THE IMPLIED WARRANTIES OR CONDITIONS OR MERCHANTABILITY OR FITNESS FOR A PARTICULAR PURPOSE. IN NO EVENT SHALL IOLINE, ITS DIRECTORS, OFFICERS, EMPLOYEES OR AGENTS BE LIABLE FOR ANY INDIRECT, SPECIAL, INCIDENTAL, OR CONSEQUENTIAL DAMAGES (INCLUDING DAMAGES FOR LOSS OF PROFITS, LOSS OF BUSINESS, LOSS OF USE OR DATA, INTERRUPTION OF BUSINESS AND THE LIKE), EVEN IF IOLINE HAS BEEN ADVISED OF THE POSSIBILITY OF SUCH DAMAGES ARISING FROM ANY DEFECT OR ERROR IN THIS MANUAL OR PRODUCT.

Limit of Liability Statement

It is the responsibility of the operator of the signcutter to monitor the performance of the signcutter and maintain it in proper working condition by following the instructions in this User Guide. It is the responsibility of the operator of the signcutter to follow all safety precautions and warnings that are described in this User Guide. Ioline is not responsible for injuries that may occur as a result of unsafe operating procedures. Ioline is not responsible for substandard operational performance as a result of failure to maintain the signcutter as described in this User Guide.

© 1997-2005 Ioline Corporation. All rights reserved. This manual may not be copied, photocopied, reproduced, translated, transmitted or converted to any electronic or machine-readable form in whole or in part without prior written approval of Ioline Corporation.

Service and Support

If you require assistance with an Ioline product, your local Ioline dealer or authorized service center is ready to help. Support information is also available 24/7 on the Ioline Web site—or you may contact Ioline directly:

Ioline Corporation
14140 NE 200th Street
Woodinville, Washington 98072 U.S.A.

Ioline Customer Service Department
Monday through Friday
7:00 A.M. - 5:00 P.M. U.S. Pacific Time
Voice: 1.425.398.8282
Fax: 1.425.398.8383
techsupport@ioline.com
www.ioline.com

SAFETY & CAUTIONS

Please read these safety guidelines before beginning operation of the signcutter. The signcutter uses a very sharp blade when cutting. The parts can move quickly. Always observe the following safety precautions:

- Do not allow the material to become suddenly taut between the plotter and a roll of material during plotting. A service loop of unrolled material is required for problem-free operation. Using the **Autoloop** function (enabled in the **Control Center**) will create the required service loop by gently pulling a set amount of material from the roll before cutting. Ioline recommends using the **Autoloop** function when plotting on a roll of material.
- Do not try to repair the machine without factory authorization. Only qualified service personnel should attempt any disassembly or access to internal components. If external mechanical adjustments are necessary, turn off the signcutter and disconnect it from all power sources (both the computer and the wall outlet).
- Be careful with hair, jewelry, or loose clothing near the signcutter. They can become caught in the mechanical parts.
- Never move the carriage by hand. Use the **Arrow** keys and let the machine do it.
- Keep hands away from the carriage when the signcutter is in operation. The carriage will automatically move to its right end position when the power is turned on.
- Be careful when lifting the signcutter. Hold the bottom surfaces of the signcutter to lift or move it.
- Keep fingers away from the drive shaft when the signcutter is in operation.
- Use caution when changing a blade in the blade holder. *See the **Routine Maintenance** chapter of the **SmarTrac User Guide** for the recommended procedure.*
- Be careful when handling the blades. They are sharp and could cause an injury if mishandled. Although the blades are made of an extremely hard material, they are brittle and can break if dropped or mishandled.

VISUAL REFERENCE GUIDE

KEY

- | | |
|------------------------------|------------------------|
| A. Dust Cover | E. Blade Holder |
| B. Drive Shaft Marker | F. LED Sensor |
| C. Idler Wheel | G. Pinchwheel |
| D. Carriage | H. Drive Shaft |

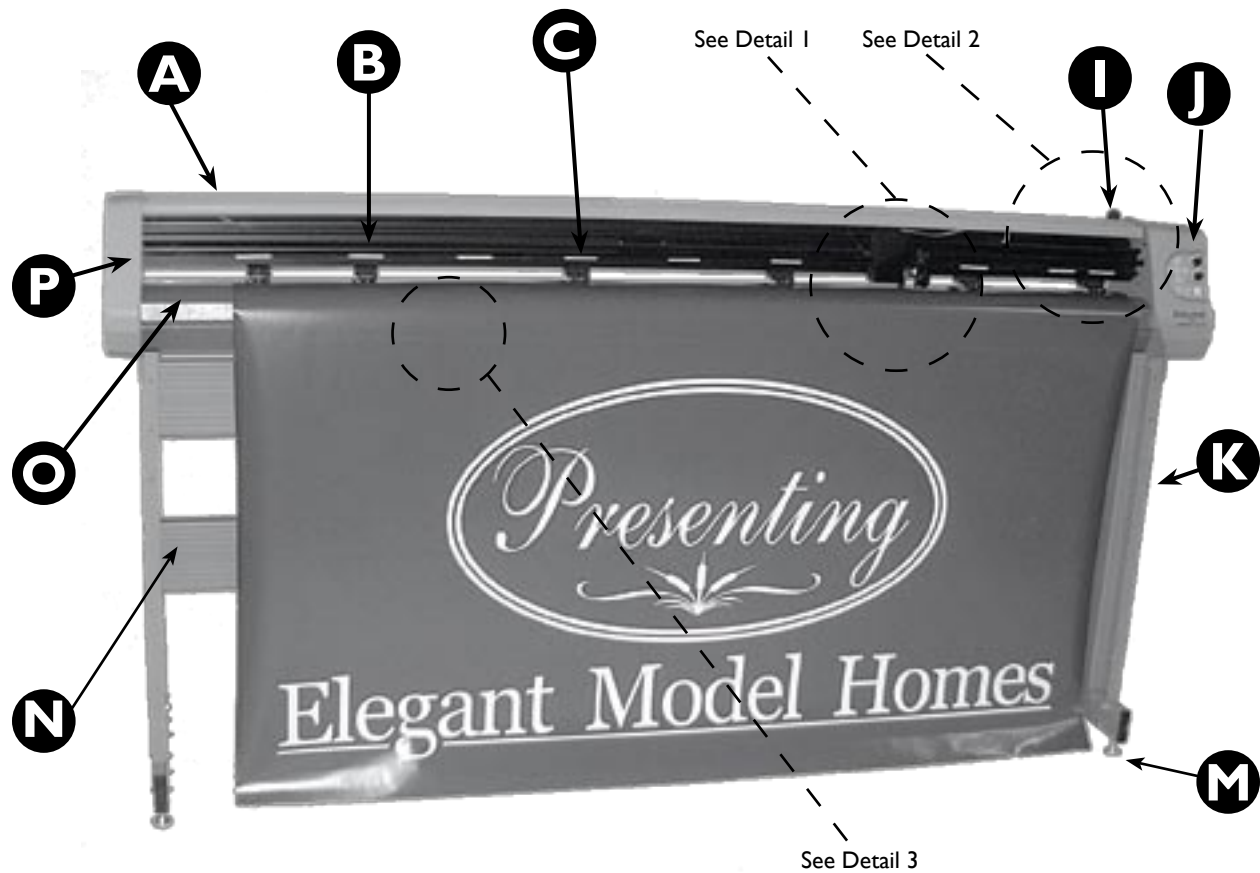
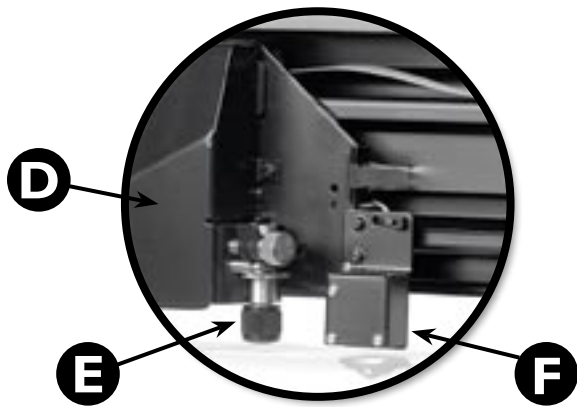

Figure 1. The Ioline SmarTrac SC-72 cutter front view.

VISUAL REFERENCE GUIDE

KEY

- | | |
|--------------------------------|--------------------|
| K. Stand Leg | O. Platen |
| L. Platen Leveling Foot | P. Traverse |
| M. Stand Leveling Foot | |
| N. Cross-member | |



Detail 1

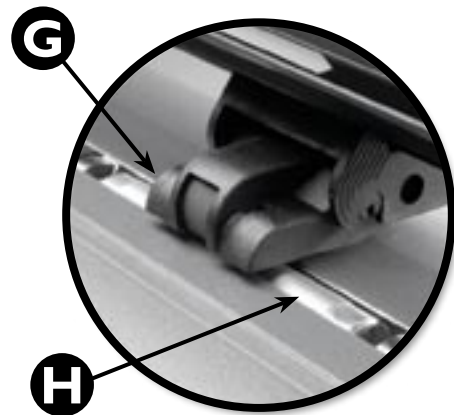

Detail 2

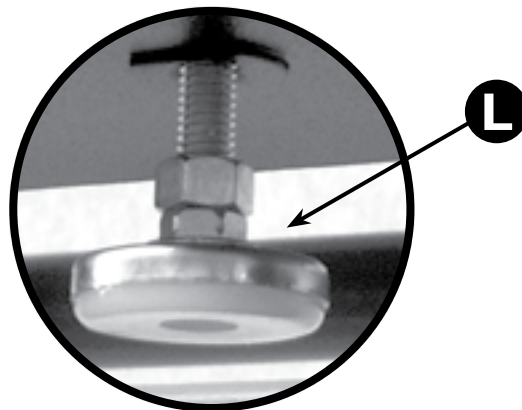

Detail 3

VISUAL REFERENCE GUIDE

KEY	
R. Power Switch	U. Power Cord
S. Serial (COM) Port	
T. USB Port	



Figure 2. Power and communications ports on the Ioline SmarTrac SC-72 are located on the back of the right cover.

Getting Started

This *Quick Start Guide* shows how to assemble and setup the Ioline SC-72 signcutter. Consult the *SmarTrac User Guide* on the CD-ROM for more detailed information about installation and operation.

Step 1: Unpack

Remove the cutter, stand parts, and **Accessory Kit** from the box. Check the **Packing List**. Always use two people when lifting the signcutter, one person at each end. Save all of the packing materials.

Required tools

- Level
- Allen wrench (included)
- 1/2-in and 9/16-in open ended or adjustable wrench

Step 2: Assemble the Stand

Prepare to Attach the Cross-members

Locate the correct holes on the stand legs to use when attaching the cross-members. Proper positioning is critical to ensure that the cutter operates as intended. Make sure the media support plates for the feed shaft point toward the rear of the machine.

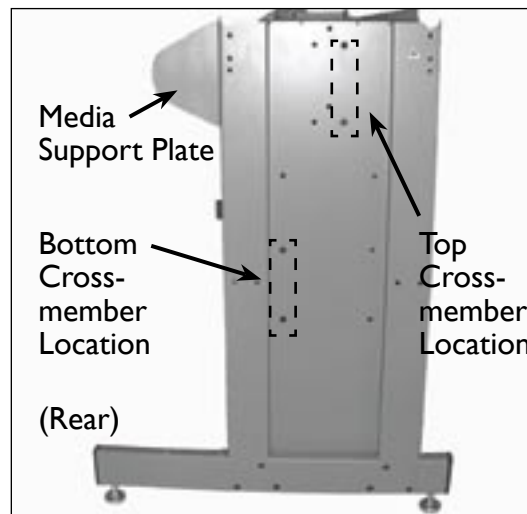

Figure 4. The media support plates should be in the back.



Note

The SmarTrac User Guide may be printed from the provided Adobe® Acrobat® viewer if necessary.

CAUTION



Caution: The SmarTrac is heavy and could cause injury if it falls. A minimum of two people are required to safely unpack the plotter and attach it to the stand or cradle. One person should hold the machine while the second person screws it to the legs.



Figure 5. Proper lifting procedure requires two people.

Connect the Cross-member and Legs

The cross-members are reversible and can be attached upside down and from either side. Hold the top cross-member against the leg. Align the holes in the leg shown in **Figure 6** with the threaded holes in the cross-member. Insert two 1-in. (medium) Phillips screws into the threaded holes.

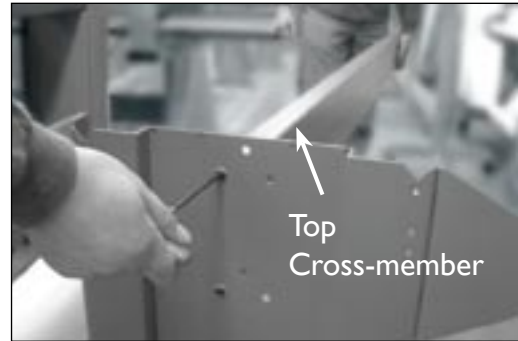

Figure 6. Connect the cross-member.

Leave them loose. Repeat this procedure for the other leg and then attach the bottom cross-member. Tighten all eight screws with the included Allen wrench.

Install the Roller Support Brackets and Rollers

Stand behind the machine and clip one of the media brackets onto the cross member about 1 foot (30 cm) from the stand leg to the right.

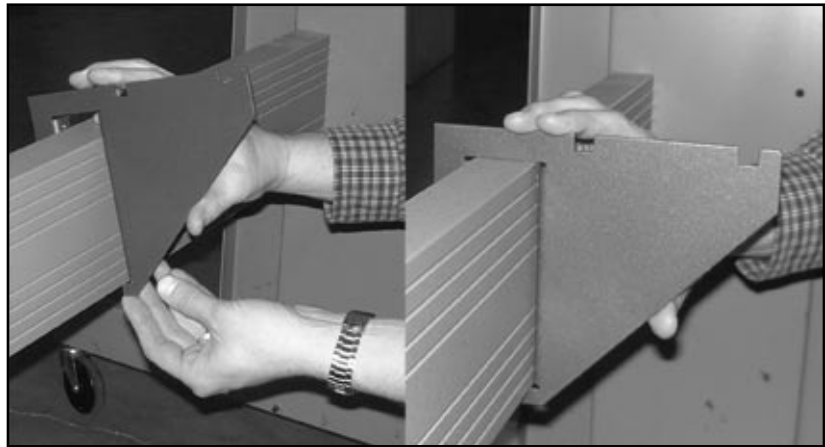

Figure 7. Attached one roller bracket from behind the machine.

Insert one of the screws from the accessory kit into the bracket then tighten it in place with a Phillips screwdriver.

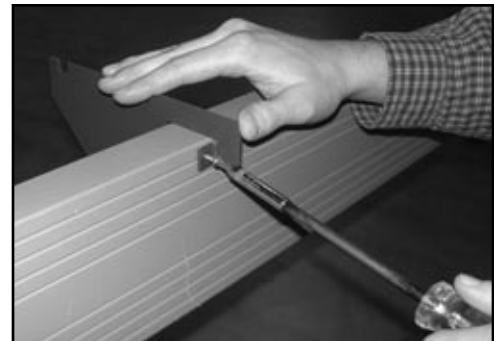

Figure 8. Insert and tighten a screw to hold the bracket in place.

Attach the second bracket about 1 foot (30 cm) from the leg to the left. Do NOT insert a screw yet. Install the hex axle of one end of a media roller into the notches in the right bracket closest to the cross member.

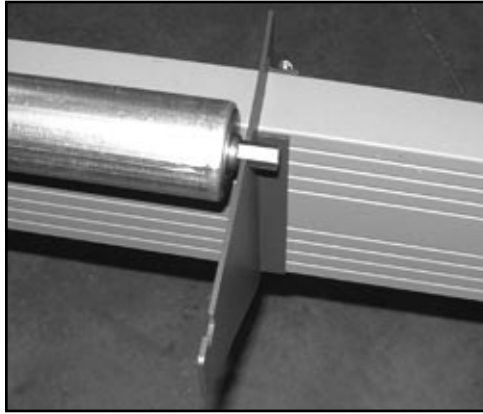

Figure 9. Install the hex axle in the roller in the notch in the right bracket.

While holding the roller up, position the hex axle at the other end of the roller over the notch in the left bracket. Move the left bracket until the roller axle fits into the notch and still rolls freely. This will determine the correct position for the left bracket. Insert one of the screws from the accessory kit into the left bracket then tighten it in place with a Phillips screwdriver.

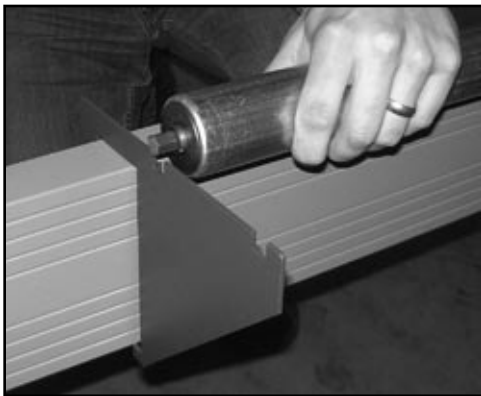

Figure 10. Move the left bracket until the roller axle rests in the notch and still rolls freely.

Install the second roller into the notches on both the left and right bracket. Make sure it rolls freely. If not, loosen screws holding the left bracket and straighten it until both rollers rotate freely.

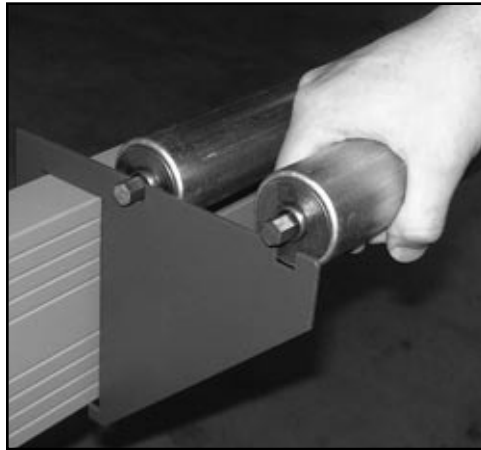

Figure 11. Install the second roller in the notches in both brackets.

Step 3: Level the Stand

1. Use the wrench to loosen the $\frac{9}{16}$ -in lock nut on both of the right leg leveling pads, turning them counter-clockwise. Place a level across the top of the right stand leg.
2. Turn the $\frac{1}{2}$ -in nut on each leveling pad to lower or raise the pad until the leg is level. Repeat **Steps 1 & 2** for the left leg.
3. Place a level on the cross-member. Repeat the adjustment procedure as above except adjust both front and rear levelers on each leg the same amount so that the legs stay level but the cross-member moves. Adjust the threaded feet until the stand is level on the cross-member.

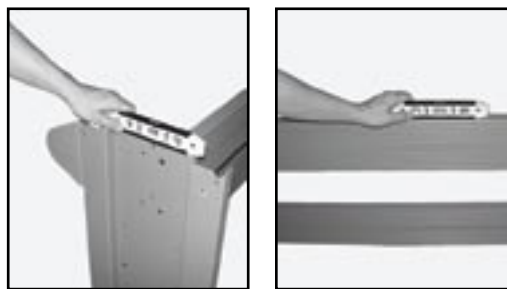

Figure 12. Level the stand legs, then the center cross-member.

4. Check the level of the legs again and make small adjustments as necessary until the stand is level in both directions.
5. Turn all of the $\frac{9}{16}$ -in lock nuts on the levelers clockwise to tighten.

Step 4: Attach Cutter to the Stand

Place Cutter on the Stand

One person should hold the cutter while the other person positions it. Slide the end plate on the bottom of the cutter inside the top of both legs. Level the stand before loosely inserting the screws to secure the signcutter head to the stand. Do not tighten them.

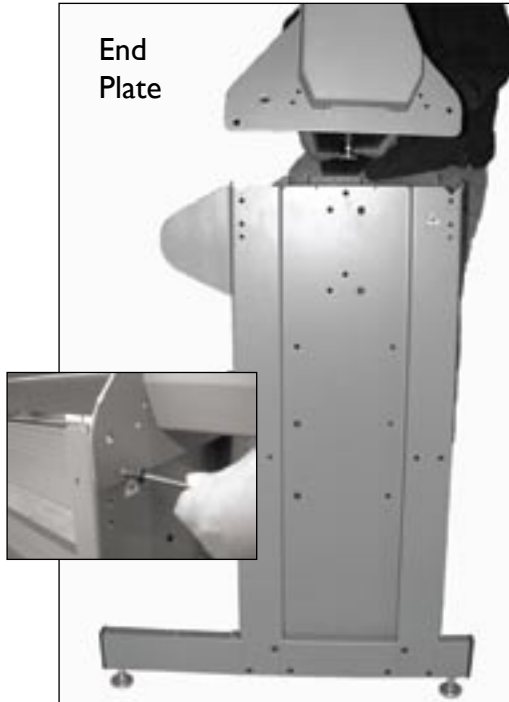



Figure 13. Line up the end plates on the signcutter with the slots on the stand legs.

CAUTION

 When placing the cutter on the stand, hold the signcutter chassis. Keep fingers away from the end plates to avoid injury.

Level the Platen

Push the pinchwheel lever back to raise the pinchwheels. Position the pinchwheels as shown in **Figure 14**, making sure they are under a white marker, then pull the pinchwheel lever forward to lower the wheels.



Figure 14. Position the pinchwheels under the white markers as shown above.

Insert the metal spacers (included in the **Accessory Kit**) between the traverse and the platen and above the levelers. Make sure the spacer is not under a white drive shaft marker and is standing vertically as shown in **Figure 15**.

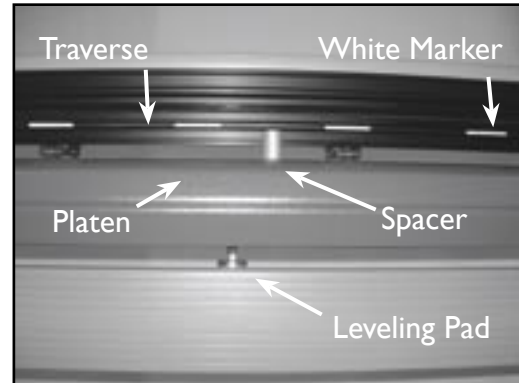

Figure 15. Position the spacers between the platen and traverse. Make sure they are not under a white drive shaft marker

Turn both leveling pads by hand until they lightly touch the cross-member, then use a $\frac{1}{2}$ -in wrench to turn the pads against the cross-members, until both spacers lightly touch the traverse.

Turn the $\frac{9}{16}$ -nuts counterclockwise by hand. Tighten with a $\frac{9}{16}$ -wrench another $\frac{1}{4}$ -turn counterclockwise as shown in **Figure 16**.



Figure 16. Adjust the platen height with the leveling pads using a $\frac{1}{2}$ -in open-ended hex wrench. Careful adjustment helps maintain proper media alignment.

Remove both spacers. Use the supplied hex wrench to tighten the four screws that hold the end plates to the stand legs, as shown in **Figure 13**.

Place a level on the platen so that it is parallel to and in front of the drive shaft. Make small adjustments to the threaded feet in the stand if the machine is not level. If the machine is difficult to level, check the printer for shipping damage and contact Ioline Customer Service. Insert the metal spacers again to verify that the platen is the right height. Adjust the feet again, if necessary.



Figure 17. Reverify that the platen is level.

Use the hex wrench to tighten the jam nuts on the leveling pad against the bottom cover of the machine. This will ensure they do not come loose during normal use.



Figure 18. Tighten the jam nut against the bottom cover after adjusting the leveling pad.

Finish Assembly

Cut the plastic strap that holds the carriage in place during shipment and discard it. Remove and discard all packing foam from around the carriage to complete the assembly.



Figure 19. Remove packing foam and plastic strip.

Step 5: Finish Installation

Install the Software and Drivers

Important: Complete the software installation process **BEFORE** connecting the USB communication cables.

Insert the installation CD-ROM into the computer CD-ROM drive. The install program should start automatically. If it does not, select **Run** from the **Start Menu**. Browse to the CD-ROM and double-click on *iosetup.exe* to start the install.

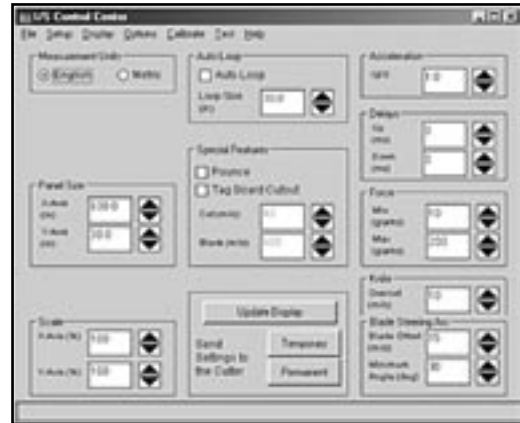

Figure 20. The Ioline Control Center.

Connect the Machine Cables

Make sure power is off to the cutter (e.g. the switch is placed in the 0 position). Connect the serial or USB cable and the power cord to the panel on the back of the cutter. (A serial cable is provided in the **Accessory Kit**.) Plug the machine power cable into a wall socket or surge protector.

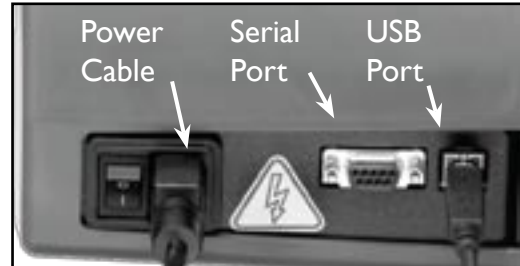

Figure 21. Power cable and communication ports.

Connect the Computer Cable

Connect the serial cable or USB cable to one of the ports on the back of the computer. Power on the Ioline equipment after the cables are installed. The carriage will seek the endplates then stop with a red keypad light.

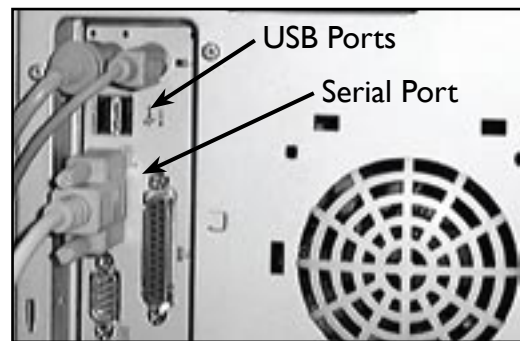

Figure 22. Computer communication ports.

Step 6: Prepare to Cut

Load the Vinyl Roll

Load the material roll onto the two media rollers so that the loose end of the media unrolls from the bottom of the roll toward the rear of the machine. It is OK if the end of the roll extends beyond the end of the roller. With the pinchwheels up, thread the vinyl through the machine.



Figure 23. Vinyl loaded on media shaft.

Position the Pinchwheels Over the Drive Shaft

Move the vinyl and pinchwheels from side to side to find a position where the outermost drive wheels are on the vinyl about 1 inch from each edge, and over a drive shaft segment. Use the drive shaft markers (Figure 24) to determine where to place the wheels.

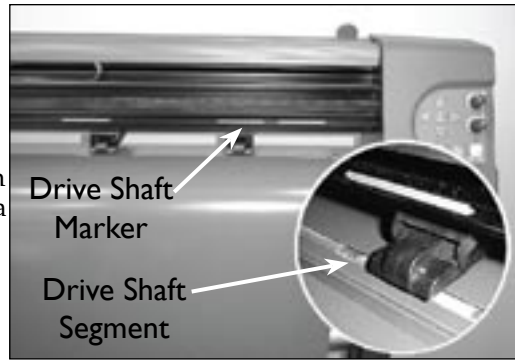

Figure 24. Place pinchwheels under drive shaft markers.

The long drive shaft segment on the right side of the machine allows many pinchwheel positions for a variety of vinyl widths. Evenly space the inner idler wheels over drive shaft segments. Make sure there is a minimum of one inch between the edge of the roll and the stand leg.

Square the Vinyl

Raise the pinchwheels using the pinchwheel lever. Make sure the vinyl is flat and square, then pull enough through the machine to align the edge of the vinyl in the front with the edge in the back. Ensure that the outer pinchwheels are at least one inch from the edge of the vinyl. Lower the pinchwheels.



Figure 25. Align the vinyl.

Position the Vinyl

Do not let the vinyl become suddenly tight between the cutter and the vinyl roll. Manually unroll a few feet of vinyl from the roll to create a slack loop behind the machine. Use the **Arrow** keys on the keypad to move vinyl through the cutter to check alignment. Adjust the vinyl if necessary so that it feeds straight. Position the vinyl edge two inches in front of the blade; Place the carriage an inch from the right edge of the vinyl.

Using the Holder in the Jaw

Unscrew the foot from the blade holder. Insert a blade into the hole in the blade holder, making sure it is fully seated. Replace the foot and adjust it so that the blade tip is barely inside the foot with no blade exposed. Loosen the thumb screw on the carriage jaw and insert the blade holder. The flange slides into the slot in the jaw. Rotate the clamp down onto the flange and tighten the thumb screw until the blade holder is held securely in place.

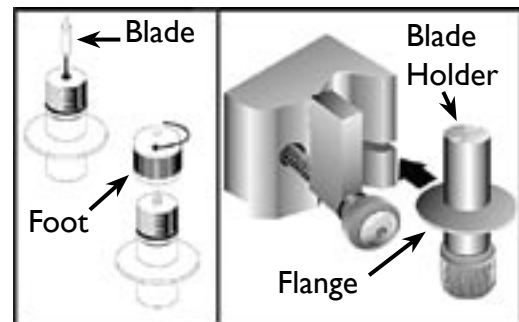

Figure 26. Inserting the blade (left) and the blade holder (right).



Note

Be very careful when handling the blades as they are sharp and brittle and the tips can chip or break. Using a hard surface to insert the blade may damage it.

Adjust the Blade Exposure and Force

Turn the **Force** knob on the keypad clockwise to maximum.

Press the **Test Cut** key. There should be little or no scoring of the vinyl. Turn the foot 1/8-turn clockwise (from the bottom). Press the **Test Cut** key. Weed the test cut pattern and examine cut quality. Continue adding

blade exposure and pressing **Test Cut** until the pattern weeds easily and the blade leaves a clear scoring on the backing.

Hint: To extend blade life, only set as much **Force** and blade exposure as is absolutely required to get a clean cut and good weed. Reduce the **Force** in small increments and perform more test cuts until the test cut pattern sticks slightly while weeding; Then, set the **Force** to the previous position. Press and hold the **Test Cut** key for 3 seconds. The cutter will cut a large test pattern as a final check. Move the carriage and vinyl to a starting position for the first file. Press the **Set Origin** key on the keypad. The light on the keypad will turn green.

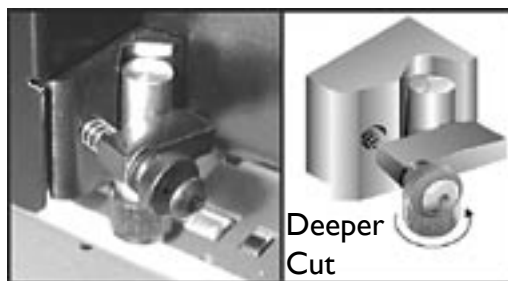

Figure 27. Adjusting the blade exposure.

The machine is ready to cut. Refer to the ***SmarTrac User Guide*** and your design software documentation for more information about optimizing cutter performance.

NOTES

NOTES

NOTES