

ASSEMBLY INSTRUCTIONS

SUPER 88 SIGNCUTTER STAND



CAUTION

- *The Super 88 is heavy and could injure you if it falls. Make sure that another person assists you in placing the plotter on the stand and holds it while it is being attached.*
- *Do not lift your Super 88 by its top dust cover or traverse rods. Use the bottom surfaces of the machine for lifting and moving your signcutter.*

YOU WILL NEED

- Phillips Screw Driver • Stand Components

STEP 1: Attaching the Crossmember

Place the crossmember on the floor with the universal legs lying at either end in an "H" pattern. The legs and crossmember are reversible and can be attached upside down and from either side. The crossmember has two threaded alignment studs on each end which fit into the large holes in the legs. Fit the crossmember snugly into the rectangular groove in the each leg with the studs inserted through the large holes. Fasten the crossmember to each leg from the outside with two 1" phillips screws.

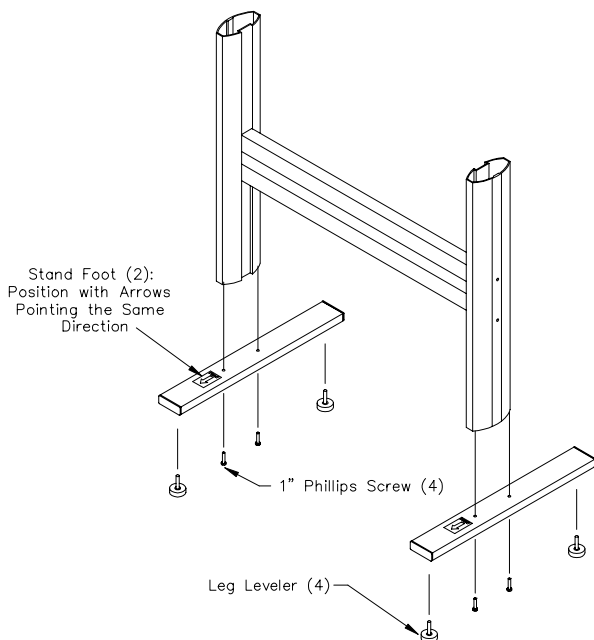
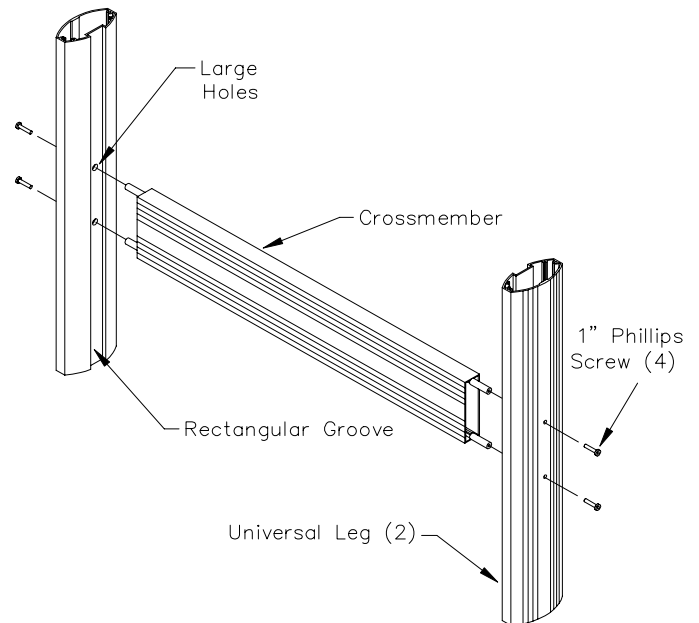

STEP 2: Attaching the Feet

Screw leg levelers halfway into the ends of the stand feet. All four levelers should be threaded in equally so that your signcutter will be level and stable. Place the assembly from **STEP 1** flat on the floor. Attach one foot to each leg using two 1" phillips screws. **MAKE SURE** that the red arrows on the feet both point in the same direction.

STEP 3: Attaching Media Roller Brackets

Stand the assembly from **STEP 2** upright on the feet. Fasten the right bracket to the top of the leg with two more 1" phillips screws. Be sure that the flat vertical portion with the notches is on the right side of the leg when the "FRONT" arrow on the foot is pointing toward you. Fasten the left bracket to the top of the leg with two more 1" phillips screws. Be sure that the flat vertical portion with the notches is on the left side of the leg when the "FRONT" arrow on the foot is pointing toward you.

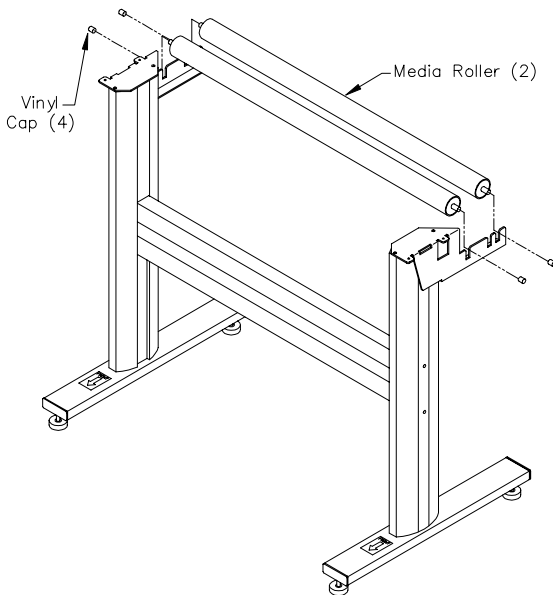
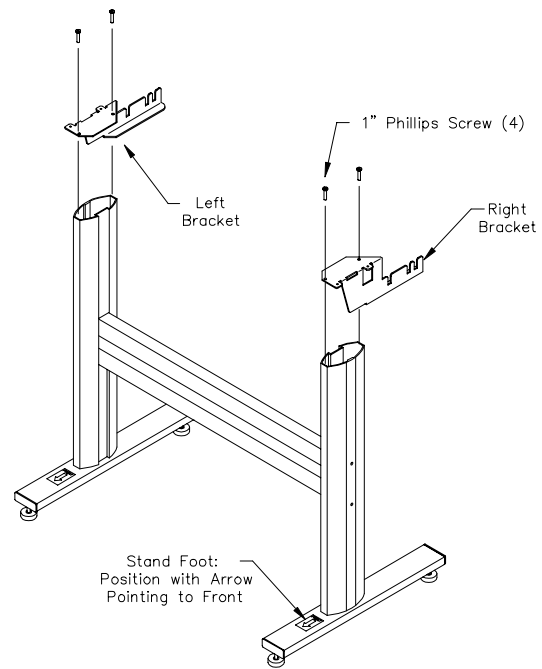

STEP 4: Attaching the Media Rollers

Insert the two media support rollers into the notches in the left and right brackets. Press the vinyl caps over the exposed ends of the support rollers.

STEP 5: Attaching the Super 88 to the Stand

Remove the screws holding the four rubber feet to the bottom of your signcutter. The feet will no longer be needed but save the hardware. Carefully lift your Super 88 over the stand making sure the front faces the same direction as the "FRONT" arrows on the stand feet. **Gently lower your signcutter into place onto the brackets and have another person hold it while attaching it to the stand.** Insert the four 3/4" phillips head screws you removed above through the left and right brackets into the base of your signcutter and tighten. Assembly is complete!

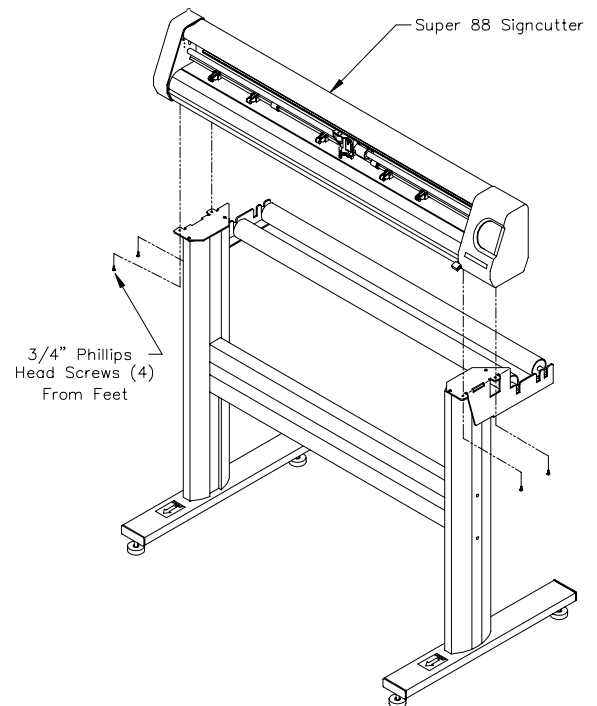

STEP 6: Removing the Arrow Stickers (Optional)

The "Front" arrow stickers on the stand feet may be removed after the stand is assembled.